

Three-phase dry type cast resin isolation transformers for medical use under IEC/EN 61558-2-15 standard for high corrosion and vibration environments.

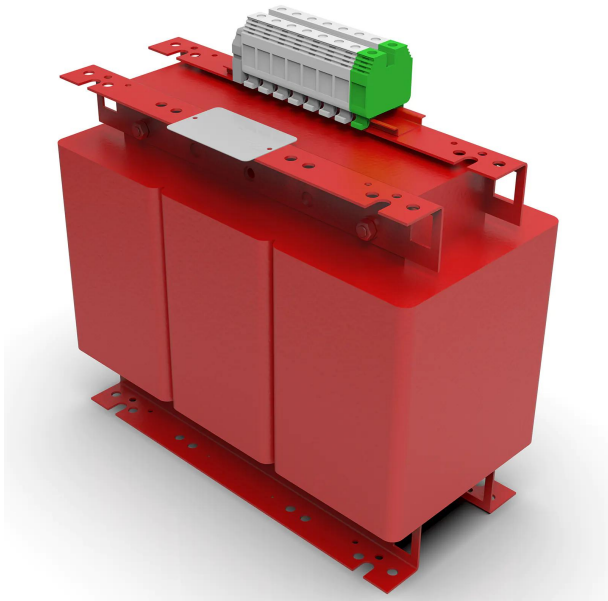

Technical characteristics

Rating	3150 VA
Input voltage	400 V
Output voltage	230 V
Frequency	50/60 Hz
Connection group	YNyn0
Protection degree	IP-20
Cooling	AN
Ambient temperature	45 °C
Inrush current	< 8In
Temperature rise	Class F - 155°C
Insulation	Class H - 180°C
Windings	Class HC - 200 °C
Test voltage	4,5 kV (1 min, 50 Hz)
No load voltage	< 3 %
Leakage current	0,5 mA (sec-earth)
Standards	IEC/EN/UNE-EN 61558-2-15, CE
Includes	Electrostatic screen between 1º & 2º and bimetal thermal protection
Weight	47,5 kg

Dimensions

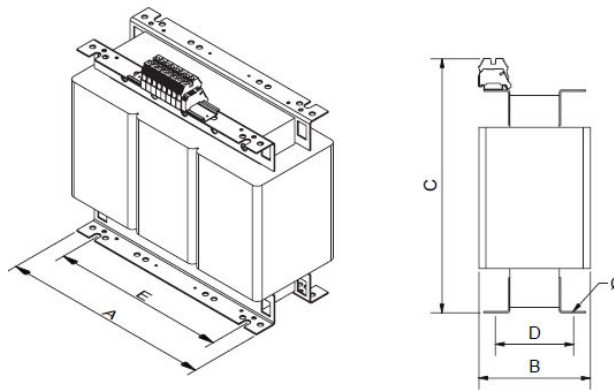

Dimensions (AxBxCxDxE): 300x154x303x145x250 mm 9Ø

Electrical connection

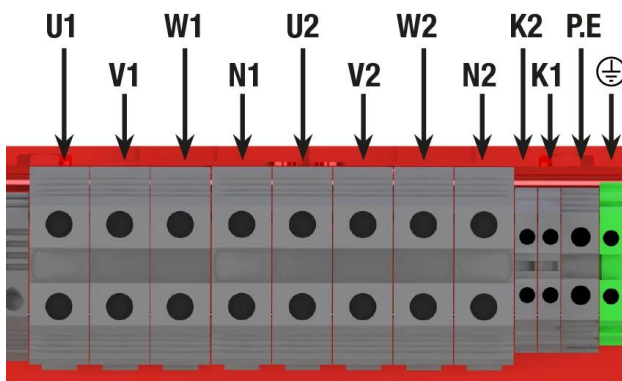

U1 = 400 V
 V1 = 400 V
 W1 = 400 V
 N1 = Neutro 1
 U2 = 230 V
 V2 = 230 V
 W2 = 230 V
 N2 = Neutro 2
 K1 = termostato klixon 150°C para 1ª bobina
 K2 = termostato klixon 150°C para 2ª bobina
 P.E = electrostatic shield

Three-phase dry type cast resin isolation transformers for medical use under IEC/EN 61558-2-15 standard for high corrosion and vibration environments.

Features

Dry type resin cast transformer

Advantages of resin technology:

- Protection against corrosive environments
- Protection against high vibration levels
- Protection against electrodynamic efforts
- Reduction of noise level
- Increase of product's lifespan

Safety class I

Includes electrostatic screen between primary and secondary terminals and bimetallic temperature sensor

Includes also lifting eyebolts from X VA

Possibility of tailor-made manufacturing

Downloads
