

Three-phase dry type ecological isolation transformers with high performance finished in anti-flash varnished for maximum protection, insulation, noise and vibration reduction.



## Technical characteristics

|                     |                         |
|---------------------|-------------------------|
| Rating              | 160 kVA                 |
| Input voltage       | 400 V                   |
| Output voltage      | 400 V                   |
| Frequency           | 50/60 Hz                |
| Connection group    | Yyn0                    |
| Protection degree   | IP-00                   |
| Cooling             | AN                      |
| Ambient temperature | 45°C                    |
| Temperature rise    | Class H - 180°C         |
| Insulation          | Class H - 180°C         |
| Windings            | Class HC - 200 °C       |
| Inrush current      | < 8In                   |
| Voltage drop        | < 2 %                   |
| Efficiency (%)      | 98,3                    |
| Noise level (dB)    | < 55                    |
| Test voltage        | 3 kV (1 min, 50 Hz)     |
| Standards           | IEC/EN/UNE-EN 60076, CE |
| Weight              | 534 kg                  |

## Dimensions

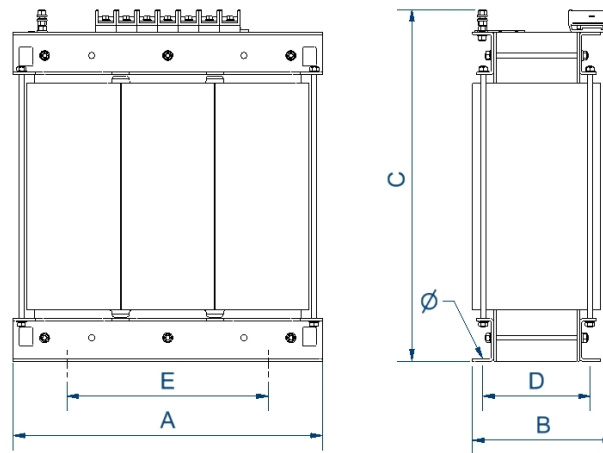

Dimensions (AxBxCxDxE): 785x550x880x460x472 mm 17

Three-phase dry type ecological isolation transformers with high performance finished in anti-flash varnished for maximum protection, insulation, noise and vibration reduction.

## Features

---

Dry type transformer

All transformers are dipped in anti-flash varnish for increased insulation and compactness.

Reduces long-term operating costs.

Low temperature rise.

Longer life than standard transformers.

Prepared for higher ambient temperatures.

Low connection peak.

Lower noise level.

Safety class I

Includes lifting eyebolts

Possibility of tailor-made manufacturing

## Applications

---

- Circuit isolation, with the possibility of increasing or reducing the voltage.
- Reducing voltage drops in installations with long cable lengths. With the installation of a step-up transformer and a step-down transformer.
- In installations with a certain level of electrical noise, the TTG series helps to improve the electrical network quality in secondary.
- Changing the neutral system of an installation
- In installations where energy savings is critical, or where a lower connection peak is required such as renewable energy plants or high energy efficiency installations.

Available accessories

- Protections in primary and secondary.
- One, two and up to 3 electrostatic screens.
- Class II
- Wheels.
- PT100, PTC or Bimetallic probes.
- Painting C5.
- Different RAL.
- Temperature control unit
- Anti condensation system
- Different IP up to IP-65

CE certificate

- **Ecotransformer**