

AUTW630 Enclosure ( 1/30 )

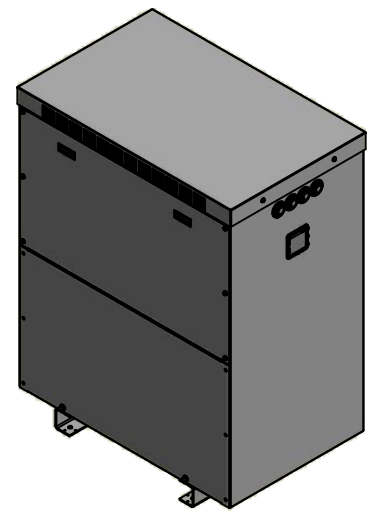

AUTW630 Transformer ( 1/20 )

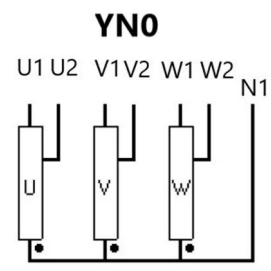
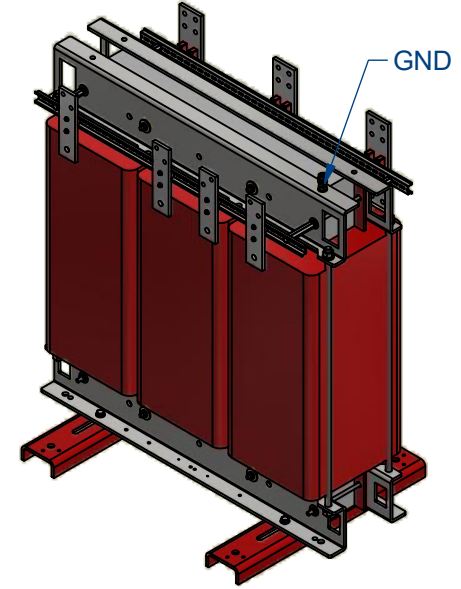

Characteristics											
IP	Vector Group	Rated power	Voltage Pri.	In Pri.	Pri. Connection	Voltage Sec.	In Sec.	Sec. Connection	Ground connection		
23	YN0	630 kVA	400 V	909,3 A	60X8 mm Al Plate Ø M12	230 V	1581,4 A	80X10 mm Al Plate Ø M12	M12 Brass stud		
Drawn by: OPS-03/01/2024		Modified by: -		Approved by: AMR-03/01/2024		Replaces:		Material: Generic	Surface treatment: N/D	Weight: 13,407 kg	Valid:
						Description: AUTW630 Drawing			Units: mm	Directory:	
						Drawing reference: PE.C.NOR.AUTW630.V02			ERP reference: AUTW630		Distributed to: