

Primary Connexion

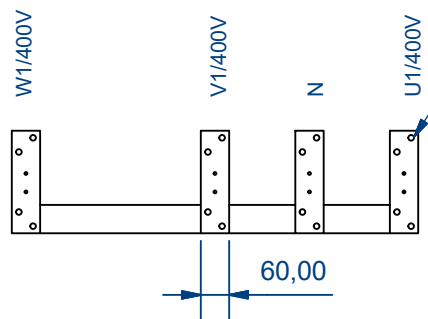

Secondary Connexion

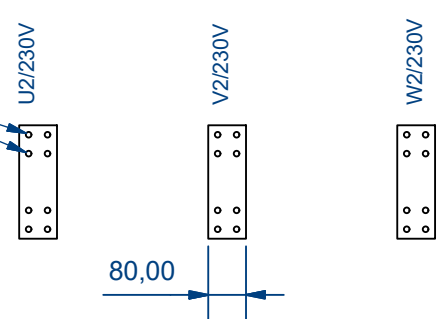

AUTW800 Enclosure (1/30)

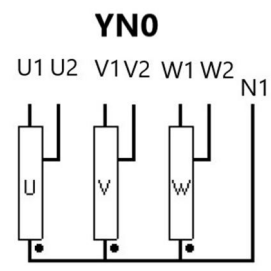
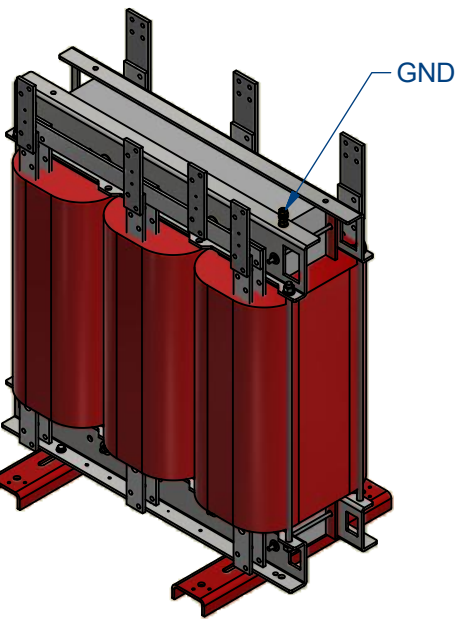
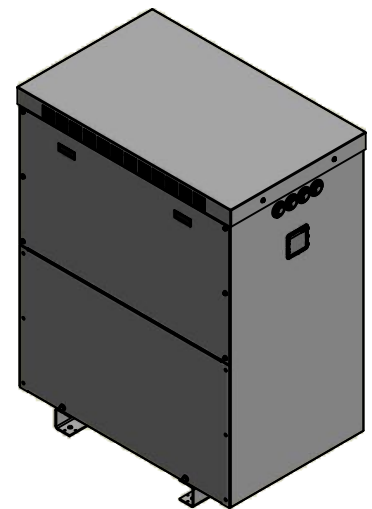

Characteristics											
IP	Vector Group	Rated power	Voltage Pri.	In Pri.	Pri. Connection	Voltage Sec.	In Sec.	Sec. Connection	Ground connection		
23	YN0	8000 kVA	400 V	1154,7 A	60X10 mm Al Plate Ø M12	230 V	2008,2 A	80X10 mm Al Plate Ø M12	M12 Brass stud		
Drawn by: OPS-03/01/2024		Modified by: -		Approved by: AMR-03/01/2024		Replaces:		Material: Generic	Surface treatment: N/D	Weight: 13,407 kg	Valid:
						Description: AUTW800 Drawing				Directory:	
						Drawing reference: PE.C.NOR.AUTW800.V01			ERP reference: AUTW800		Distributed to: