

1 2 3 4 5 6 7 8

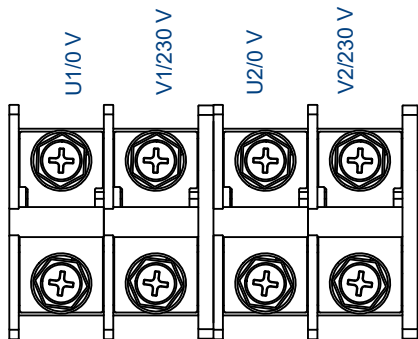

Connexion (1/2)

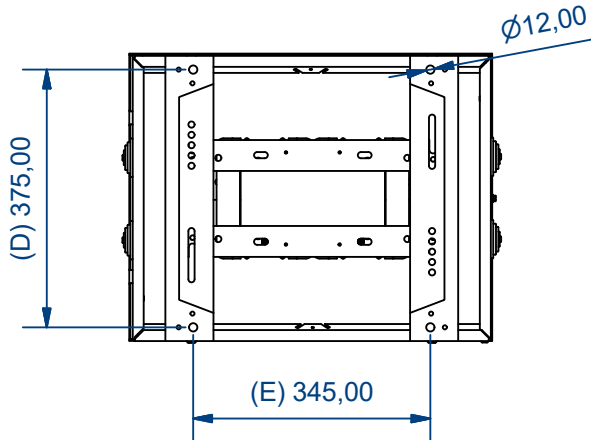

TKW20 Transformer (1/8)

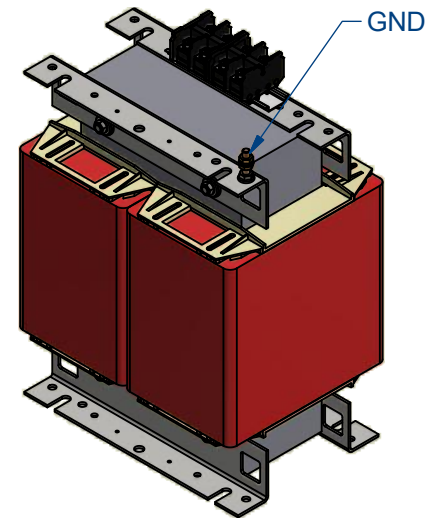

A

A

B

B

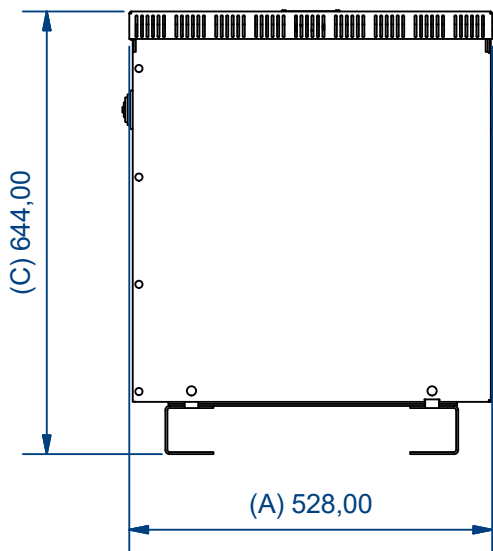
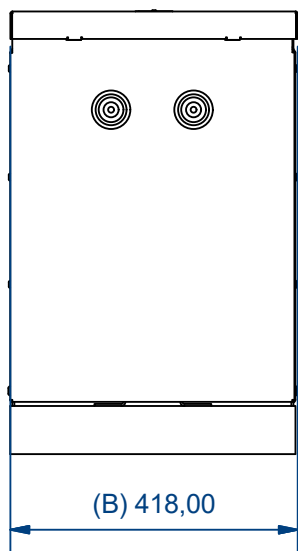

TKW20 Enclosure (1/18)

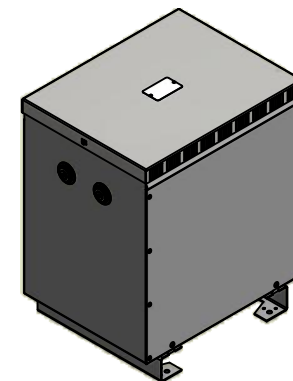

C

C

D

D

Characteristics								
IP	Rated power	Voltage Pri.	In Pri.	Pri. Connection	Voltage Sec.	In Sec.	Sec. Connection	Ground connection
23	20 kVA	230 V	87,0 A	M8 Terminal Max. width 22,5mm	230 V	87,0 A	M8 Terminal Max. width 22,5mm	M8 Brass stud
Drawn by: OPS-09/01/2024		Modified by: -		Approved by: AMR-09/01/2024		Replaces:		Material: Generic
				Description: TKW20 Drawing		Surface treatment: N/D		Weight: N/D
Drawing reference: PE.C.NOR.TKW20.V01		ERP reference: TKW20		Distributed to:		Technical D. Commercial D.		Scale: 1 / 11
						Customers		Page: 1 / 1

1 2 3 4 5 6 7 8